

Network Video Recorders

NVR-AS 3000 FD Series

Powerful and integrated recording and playback system for video and audio from IP cameras and transmitters.



NVR-AS 3000 Fixed Disk Series:
FD1000 / FD2000

IndigoVision offers a suite of Network Video Recorders to suit your requirements. Our family of Standalone Network Video Recorders provides a powerful and integrated recording and playback system for video and audio from IP cameras and transmitters, with a choice of integrated or removable disks.

All Standalone IndigoVision NVRs can be rack- or desk-mounted and require no additional hardware for operation. They can be located at any point on a network allowing recording and playback across multiple sites regardless of location. A system can deploy as many NVRs as required. Remote NVR management and configuration is performed using an intuitive web-based configuration interface which forms part of IndigoVision's Control Center software.

- Record and playback MPEG-4 and H.264 video and audio streams
- Simultaneous full frame rate recording of up to 64 streams plus playback of up to 20 streams
- 5-Year Disk Warranty
- Redundant network connections
- Internal power supply with redundant power connector
- Optional RAID storage resilience
- Low power / low cost of ownership

Specification

	FD Series	
	1000	2000
Network Redundancy	Y	Y
Redundant Power Supply	Y	Y
Removable Storage	N	N
Disk Space (GB)	1000	2000
Available Storage (GB)	963	1953
RAID	RAID 0	RAID 0
Max. Recording Streams	64	64
Max. Playback Streams	20	20
Max. Recording Bitrate	64	64
Max. Playback Bitrate	40	40
Licence Options	20 stream, 40 stream and 64 stream licenses are available	
Power consumption	39W max	
Physical Dimensions	483x272x87mm (2U)	
Electrical	Operating Voltage: Input 100-240V ~ 47-63Hz 1A. Connector for redundant external power supply	
Network Connections	Two redundant 100/1000 BaseT RJ-45 Connections	
Environmental	Operating temp: 0° to 50°C/32° to 122°F; Storage temp: -20 to +70°C/-4 to +158°F	
Onboard Diagnostics	Disk, CPU, Motherboard temperatures. Redundant power and network status. Cooling fan status	
Regulatory	EN55022 ITE Emission standard Class A; EN61000-3-2 Mains Harmonics Class A; EN61000-3-3 Voltage Fluctuation; EN55024 ITE Immunity standard; CFR47: 2002 Part 15 Sub Part B (US federal code of regulations) UL 60950-01, Information Technology Equipment - Safety - Part 1: General Requirements	
Disks	SATA Seagate SV35.5 Series optimised for 24x7 video storage. 5-year warranty	

Examples of Recording Duration in Days

This table estimates the number of days recording on an FD2000 model (2TB storage) with different numbers of cameras assuming full frame rate, 4SIF, H.264 video at a maximum bitrate of 2Mbps. As IndigoVision transmitters only use required bandwidth, the actual recording capacity may be more or less than shown.

For more accurate estimates, please see the IndigoVision website or contact IndigoVision's Partner Support.

Motion level	16 cameras	32 cameras	64 cameras
Occasional	100 days	50 days	25 days
Intermittent	20 days	10 days	5 days
Frequent	10 days	5 days	2 days



Specification

All NVR-AS 3000 variants have the same 2U high, 19" rack housing design with different storage configurations depending on the variant.



View on back face

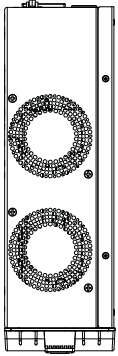

View on left face

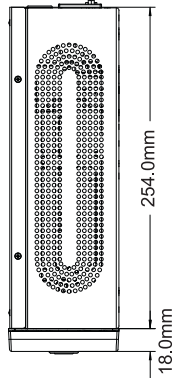

View on right face

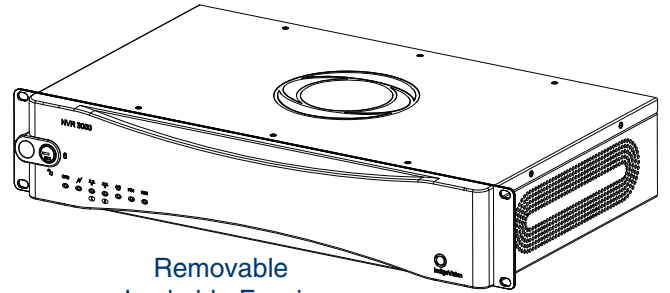

Removable
Lockable Fascia

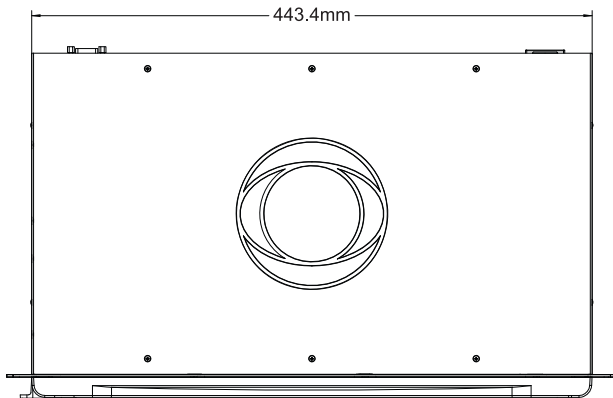

View on top face

Front Faces with Fascia Removed



FD Series with 2 x Fixed Internal H/Drives

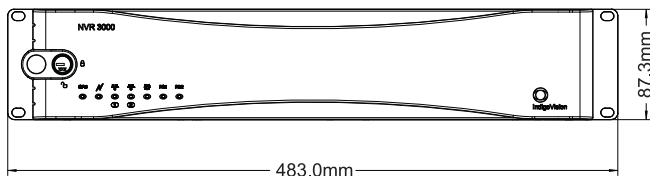

View on front face